

REV.	ECN. NO.	APPD.

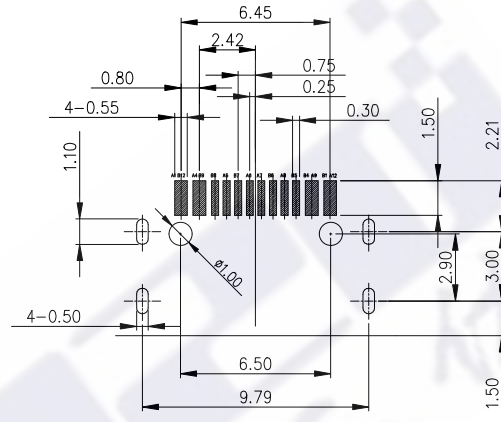

NOTES:  
SPECIFICATION:

1. CURRENT RATING: 3.0A MAX
2. DIELECTRIC WITHSTAND VOLTAGE: 100VAC
3. TEMPERATURE RANGE: -30 °C ~ 85 °C
4. CONTACT RESISTANCE: 40 MILLIONHM MAX
5. INSULATION RESISTANCE: 100 MEGOHMS MIN.
6. INSERTION FORCE : 5N~20N
7. UNMATING FORCE: 8N~20N
8. DURABILITY: 10,000 CYCLES

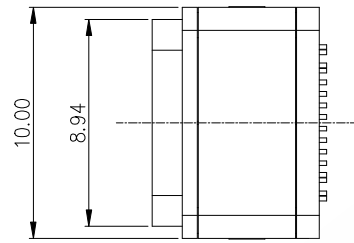
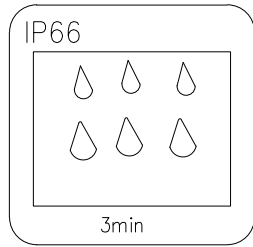
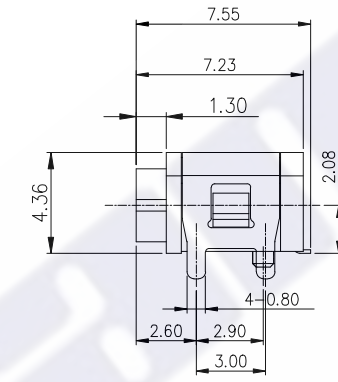
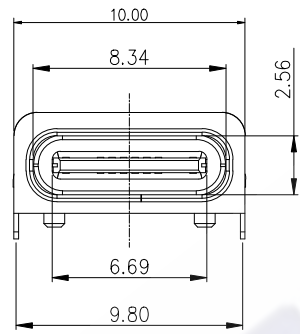

RECOMMENDED P.C.B. LAYOUT  
TOLERANCE UNSPECIFIED ±0.05mm

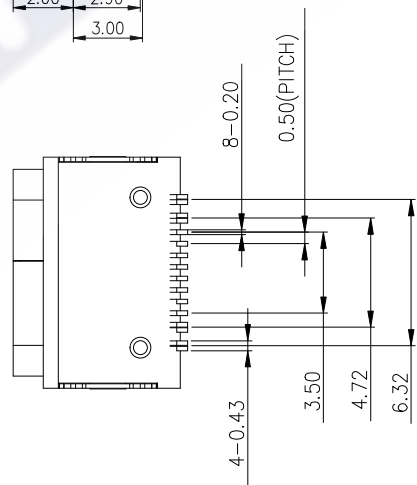
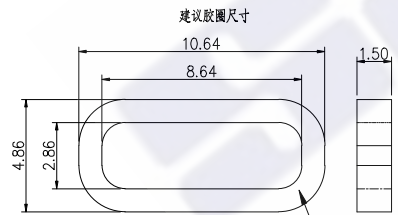
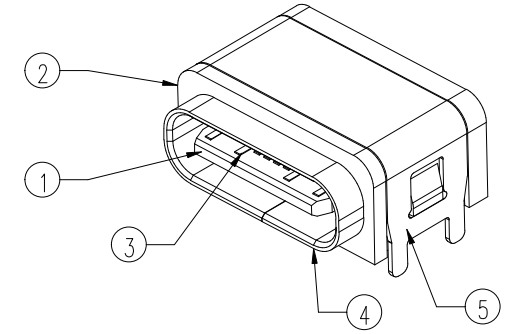
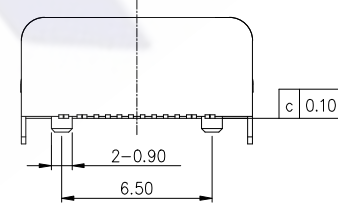

NO.	DESCRIPTION	MATERIAL	REMARKS	QTY
6	镀金层	金胶	BLACK	1PCS
5	SHELL	STAINLESS STEEL	Ni Plated	1PCS
4	SHIELDING PLATE	STAINLESS STEEL	Ni Plated	1PCS
3	CONTACT	COPPER ALLOY	Au/Ni Plated	1SET
2	SHELL HOUSING	HIGH TEMPERATURE PLASTIC	BLACK	1PCS
1	HOUSING	HIGH TEMPERATURE PLASTIC	BLACK	1PCS

A1	GND	B12	GND
A4	VBUS	B9	VBUS
A5	CC1	B8	SBU2
A6	DP1	B7	DN2
A7	DN1	B6	DP2
A8	SBU1	B5	CC2
A9	VBUS	B4	VBUS
A12	GND	B1	GND
PIN	SIGNAL NAME	PIN	SIGNAL NAME

The copyright belongs to samzo parts [China] Co., Ltd. please use the material after samzo parts agree to authorize. The final right of interpretation belongs to samzo parts.

X.	± 0.50	X.'	± 2'
.X	± 0.30	.X'	± 1'
.XX	± 0.10	.XX'	± 0.5'
.XXX	± 0.05		

UNITS: mm

MAT'L: /

FINISH: /

Q'TY: /

三佐部品【中国】股份有限公司

PART NO.: MTKEF16WD1BDWNG1N

TITLE: TYPE C 2.0 16Pin SMT Type

APPD: RADOM

CHKD: MARK

DW NO.: MTKEF16WD1BDWNG1N

DR: JANE CHOU 2020/09/26

SCALE	SHEET	REV.
1/1	1/2	A2

A

B

C

D

E

A

B

C

D

E

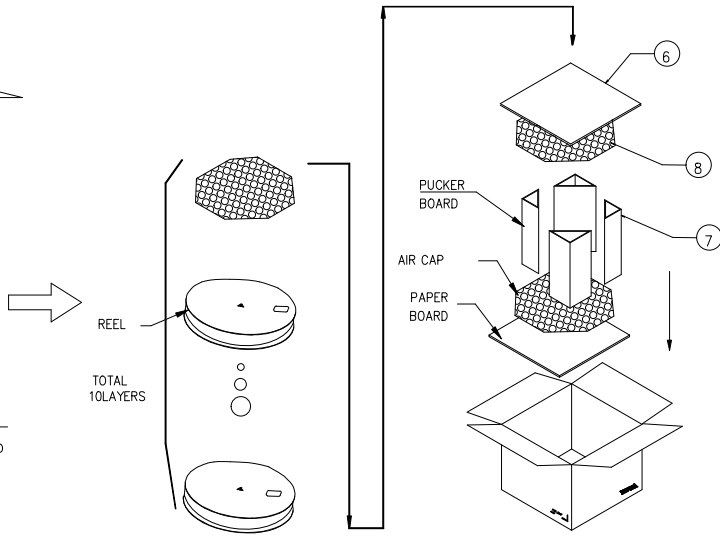
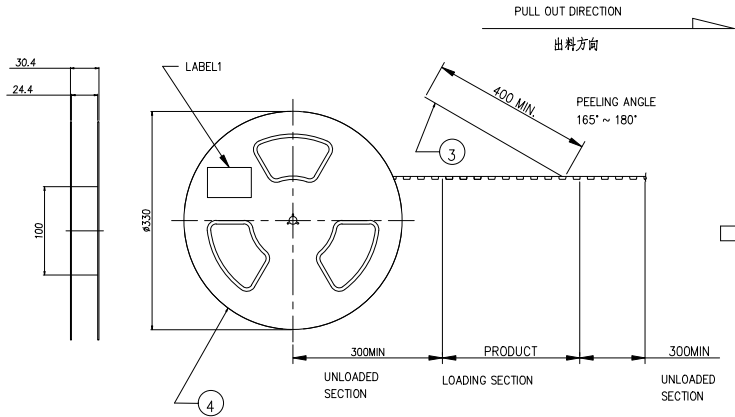

备注:  
 1. 包装方式  
 1-1: 使用半自包, 先 CARRY TAPE 送入中, 并 COVER TAPE 合在上面, 其中前端20空槽不要放品, 尾端20空槽不要放品, 然后品如所示方向依次放入 CARRY TAPE 每槽放1PCS;  
 1.2. 用 CARRY TAPE 合在一起, 真空包装后在图示指定位置上 LABEL;  
 1-3: 按图要求将10盘包装好的 REEL 套入防水袋后装入纸箱, 纸箱上下按图要求加垫硬纸板和海绵垫, 四角折三角垫固定;  
 1-4: 将装好产品的纸箱按图要求封箱, 在指定区域贴好 LABEL;

2. 包量:  
 900PCS/REEL;  
 10REEL(9000PCS)/CARTON.

3. 耐剥离性:  
 上带引拔力测试规格: 20-150gf  
 测试条件: 以每分钟300mm速度引拔测试

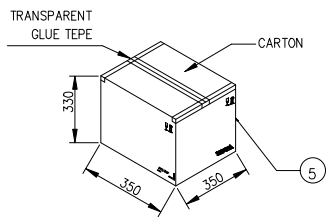
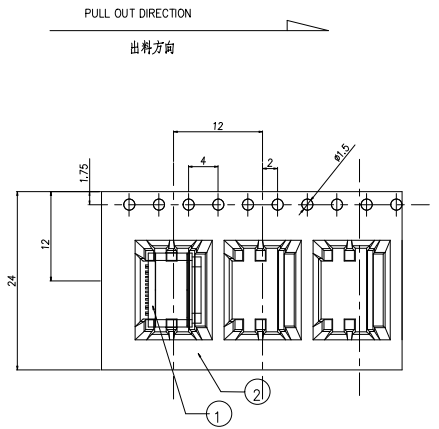

8	气泡垫	L=345,W=345,T=10	2PCS
7	纸板(折三角垫)	L=430,W=330,T=6	4PCS
6	硬纸板	L=330,W=330,T=6	2PCS
5	外箱	L=350,W=350,H=330	1PCS
4	卷盘	PS,BLUE,A=330,B=100,W=32.4	10PCS
3	上带	PET,CLEAR,W=21.3	11.5m
2	载带	PS,BLACK,W=24,T=0.4,P=16	11.5m
1	UAB CONN	UAB CONN	9000PCS
NO.	NAME	SPEC	Q'TY

						Angle	±2'	DESIGN	李元球	2021.06.01	三佐部品【中国】股份有限公司		
						.x	±0.30	CHECK			TITLE:	TYPE-C USB CONN	
						.xx	±0.25	APPROVAL			MODEL NO.	MTKEF16WD1BDWNG1N包装规范	
ECN NO.	REV	DATE	DESCRIPTION	CHANGE	APPRO.	.xxx	±0.10	SCALE:	3:1	UNIT:mm	A4	SHEET: 1 of 2	
						GENERAL TOLERANCE UNLESS OTHERWISE NOTED						FILE NO.	Q/DY.QW-WP-XXX